

RK-NEEDLE VALVE

NVFK-HP, DN4 - DN10, PN250

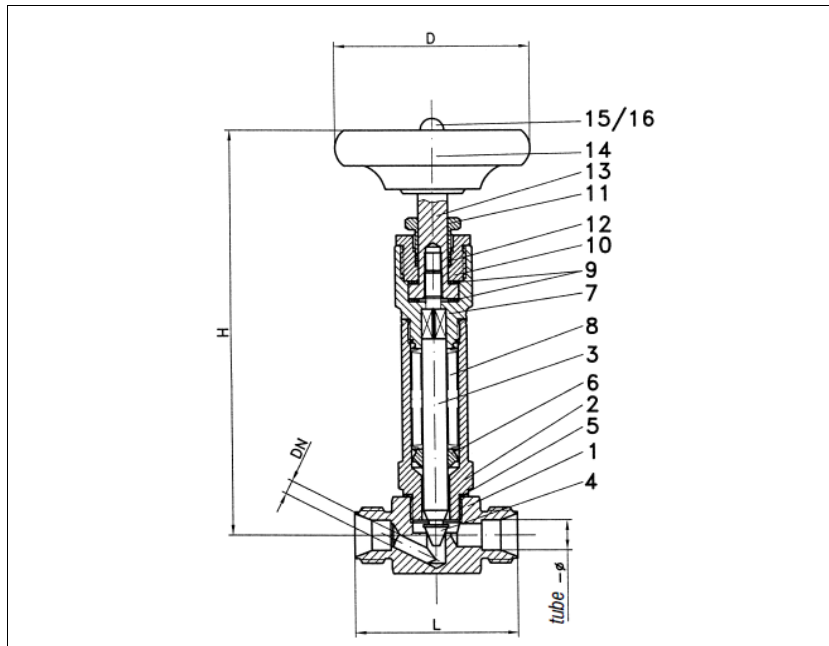

High pressure needle valve with clamping ring connection and bellow face to face acc. to producers standard

Specification:

High pressure needle valve with clamping ring connection PN 250, fully welded bellow and safety stuffing box above, body made of acid resistance forged steel (1.4571), metal tight conical globe, metal resealing, anti blow out spindle, bellow made of 3 layers fully welded, hardened shaft beared with PTFE coated friction discs, gland nut metal tight on block, stuffing box material KF or graphite, design free of non ferrous metals, clean air act confirmation, 10.000 cycles warranty.

Marking: RK-Needle valve
Type: NVFK-HP-1.4571

No.	Part	Material 1.4571-KF	Material 1.4571-Graphite
1	body	1.4571	1.4571
2	bonnet	1.4571	1.4571
3	spindle	1.4571	1.4571
4	globe	1.4571	1.4571
5	body seal	1.4571	1.4571
6	below connector	1.4571	1.4571
7	upper connector	1.4571	1.4571
8	bellow	1.4571	1.4571
9	friction disc	1.4571/PTFE	1.4571/PTFE
10	gland nut	1.4571	1.4571
11	stuffing box	1.4571	1.4571
12	packing	KF	Graphite
13	shaft	1.4571	1.4571
14	hand wheel	synthetic FS31	synthetic FS31
15	washer	1.4571	1.4571
16	nut	1.4571	1.4571

Dimensions

DN	PN	tube-Ø	dimensions in mm		
			L	H	D
4	250	6	60	151	80
5	250	8			
5	250	10			
6	250	12	65	151	80
8	250	15			
10	250	18	80	154	

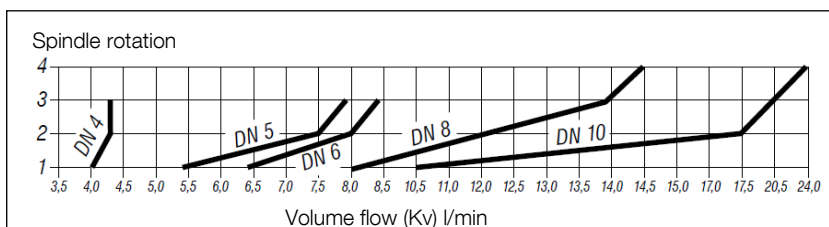
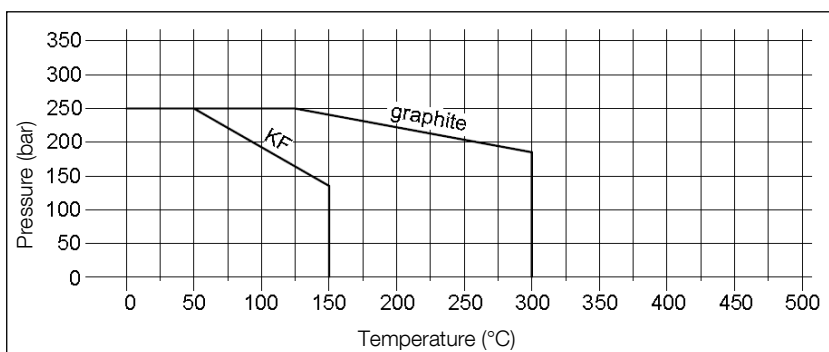

Ordering example:
NVFK-HP-1.4571-Graphite, DN8, PN250

Subject to modification. 11/2023